



1GM10 Series

Configuration	4-stroke, vertical, raw water-cooled diesel engine		
Maximum output at crankshaft	* 6.7 kW@3600 rpm	[9 mhp@3600 rpm]	
	** 6.6 kW@3600 rpm	[9 mhp@3600 rpm]	
Displacement	0.318 ltr	[19.41 cu in]	
Bore x stroke	75 mm x 72 mm	[2.95 in x 2.83 in]	
Cylinders	1		
Combustion system	Indirect injection [special swirl type pre-combustion chamber]		
Aspiration	Natural aspiration		
Starting system	Electric starting 12V - 1.0 kW with manual combination		
Alternator	12V – 40A		
Cooling system	Direct seawater cooling by rubber impeller seawater pump		
Lubrication system	Enclosed, forced lubricating system		
Direction of rotation [crankshaft]	Counterclockwise viewed from flywheel side		
Dry weight with gear	76 kg	[168 lbs]	
Environmental	EU: RCD	BSO II	EMC
Engine mounting	Rubber type flexible mounting		

NOTE:Fuel condition: Density at 15°C = 0.84 g/cm³; 1 kW = 1.3596 mhp = 1.3410 HP

* Fuel temperature 25°C at the inlet of the fuel injection pump [ISO 3046-1]

** Fuel temperature 40°C at the inlet of the fuel injection pump [ISO 8665: 2006]

Technical data is according to ISO 8665: 2006/3046-1

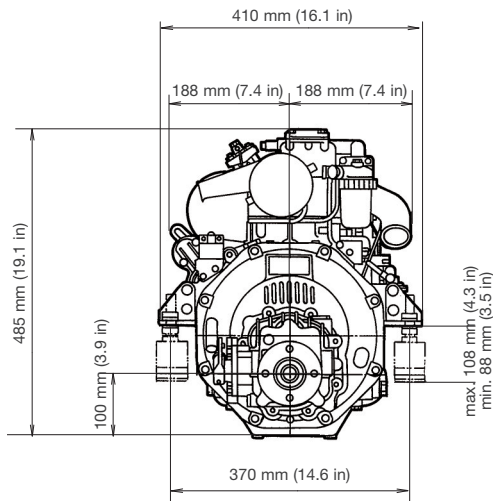
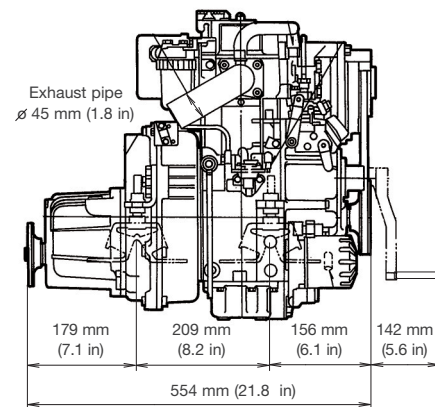
DIMENSIONS**Rear view****Right side view**

1GM10 with KM2P-1 marine gear



PERFORMANCE CURVES

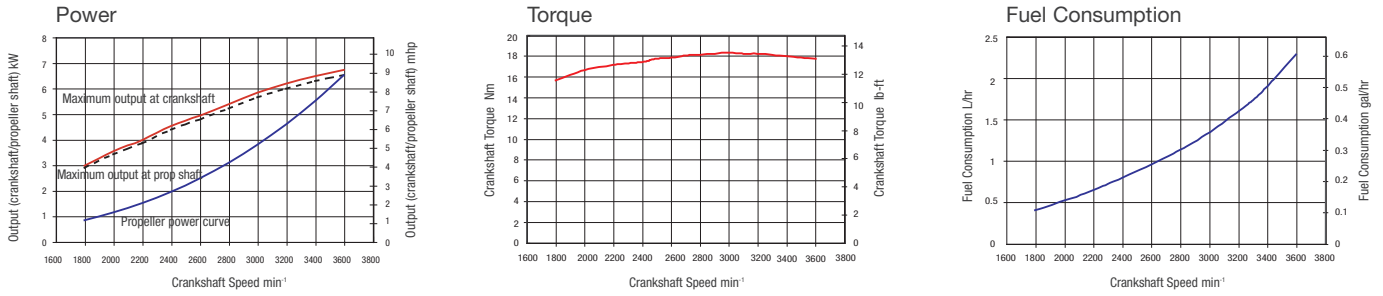

MARINE GEARS/DRIVE

Model	KM2P-1		SAILDRIVE [SD25]
Type	Constant mesh gear with servo-cone clutch		Constant mesh gear with dog clutch
Dry Weight	10 kg [22 lbs]		30 kg [66 lbs]
Reduction Ratio [fwd/asn]	2.21/3.06	2.62/3.06	2.64/2.64
Propeller speed [fwd/asn]	1629/1176	1374/1176	1364/1364
Direction of rotation	Clockwise		Counterclockwise
[propeller shaft - fwd]	viewed from flywheel side		viewed from flywheel side
Dry weight - engine & gear	76 kg [168 lbs]		104 kg [229 lbs]
Length engine and gear/drive	554 mm [22 in]		723 mm [29 in]

INSTRUMENT PANELS

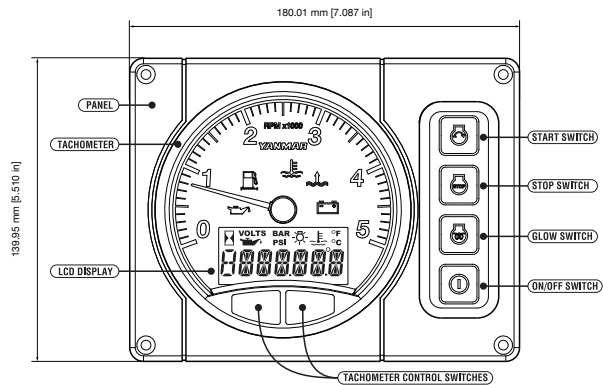
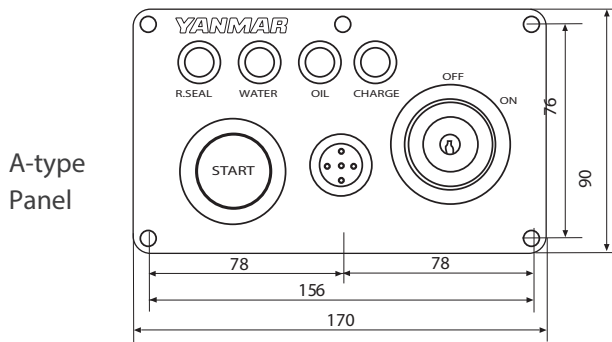

ACCESORIES

Standard engine package

- Sensor for instrument panel
- Rubber type flexible mounts
- Exhaust mixing elbow [L-type]
- Alternator 60A

Optional accesories

- A-panel
- B20-panel
- Various extension wire harnesses
- Propeller cone nut kit SD25

NOTE: All data subject to change without notice. Text and illustrations are not binding.